

Typical Applications Audio and Visual Equipments : CD/MD Player / Car CD Player / Camcorder
 Household Appliances : Blood Pressure Meter
 Office Automation Equipments : CD/DVD-ROM Drive

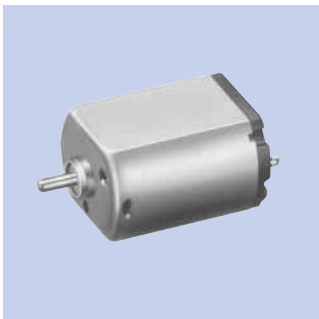

MODEL	VOLTAGE		NO LOAD		AT MAXIMUM EFFICIENCY					STALL		
	OPERATING RANGE	NOMINAL	SPEED	CURRENT	SPEED	CURRENT	TORQUE		OUTPUT	TORQUE		CURRENT
			r/min	A	r/min	A	mN-m	g-cm	W	mN-m	g-cm	A
FF-030PA-10180	3.5 ~ 6.0	5V CONSTANT	11700	0.050	9230	0.19	0.50	5.1	0.48	2.35	24	0.70
FF-030PK-09210	1 ~ 5	5V CONSTANT	10500	0.046	8140	0.16	0.44	4.5	0.37	1.96	20	0.55
FF-030PK-08250	1 ~ 6	2.5V CONSTANT	4100	0.028	2940	0.071	0.21	2.1	0.064	0.74	7.6	0.18
		6V CONSTANT	10500	0.041	8020	0.13	0.43	4.4	0.36	1.81	19	0.43
FF-030PN-09210	4.5 ~ 6.0	5V CONSTANT	10400	0.045	8000	0.15	0.42	4.3	0.35	1.81	19	0.50

UNIT: MILLIMETERS

DIRECTION OF ROTATION

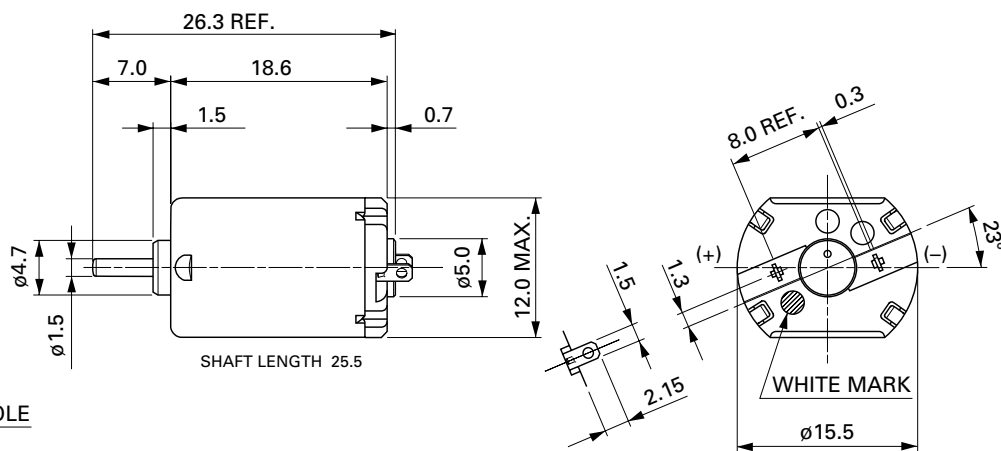
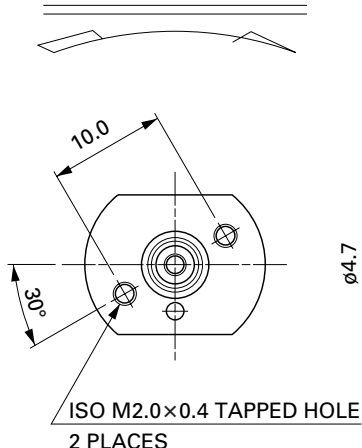

WEIGHT: 11g (APPROX)

FF-030PA-10180

5.0V

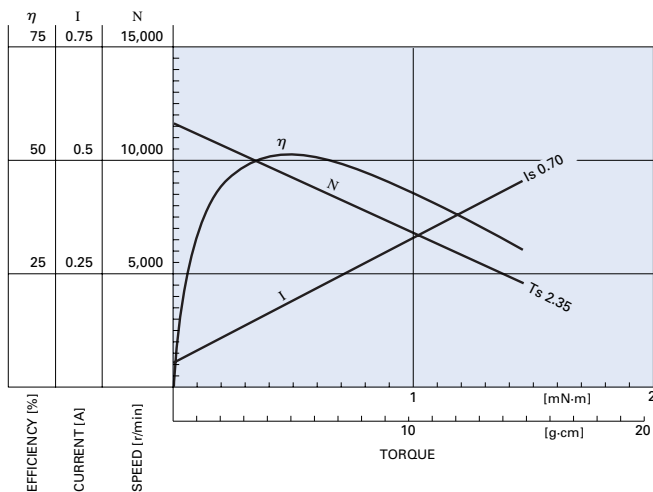

FF-030PK-09210

5.0V

